

See discussions, stats, and author profiles for this publication at: <https://www.researchgate.net/publication/343721724>

Design and Analysis of Pneumatic Operated Bed for Hospitals

Article in *The International Journal of Industrial Engineering: Theory, Applications and Practice* · October 2019

CITATIONS

0

READS

1,149

3 authors:



Omar Adel Abdallah

Qatar University

1 PUBLICATION 0 CITATIONS

[SEE PROFILE](#)



Abubacker K. M.

National University of Science and Technology, Oman

8 PUBLICATIONS 11 CITATIONS

[SEE PROFILE](#)



Veerasamy Suresh Babu

College of Engineering, National University Oman

14 PUBLICATIONS 62 CITATIONS

[SEE PROFILE](#)

Some of the authors of this publication are also working on these related projects:



Non-symmetric Gear Matlab GUI [View project](#)



Low cost automation [View project](#)

Research Article

Design and Analysis of Pneumatic Operated Bed for Hospitals

Omar Adel Mustafa Abdallah^{1*}, K. M. Abubacker², V. Suresh Babu²

¹Graduate from College of Engineering, National University of Science and Technology, Muscat, Oman.

²Senior faculty in College of Engineering, Department of Mechanical and Industrial Engineering, National University of Science & Technology, Muscat, Oman.

*Corresponding author's e-mail: sureshbabu@nu.edu.om

Abstract

The hospital beds are one of the most important units in any hospital around the world. These beds help doctors and nurses in positioning the patients as required during the treatment of patients. To engineer the treatment bed in hospitals, the present work aims to develop a mechanism for tilting the beds by using pneumatic system to achieve five different positions. These positions are achieved by actuating the corresponding double acting cylinders attached to the bed to attain different inclinations for front, back, right, left and total bed movements. FESTO fluids3.6 Computer Software is used to design and simulate the pneumatic circuit of the system. The pneumatic system has been designed by using a set of pneumatic components such as compressor, 3/2-way valves with push buttons and 5/2-way valves. PTC CREO has been used to model the mechanical parts of the hospital bed. Analysis and simulation of the hospital bed model has been carried out. The results of the analysis have proved that the pneumatic system is safe to use in the hospital bed which can withstand a maximum load of 300 kg.

Keywords: Pneumatic system; PTC CREO; Festo fluids3.6; Hospital treatment bed.

Introduction

Medical treatment beds are very important units in any hospital around the world. It helps the medical team to deal with patients during treatment and helps to provide comfort to the patients [1]. It has been observed that for certain surgery process sometimes the medical teams have to force the patients manually to keep in a certain position. When placing the patient manually to the required position, the chances of hurting the patient increase. So, in developing a smart medical bed, the process of positioning the patient will be more easy and safe for the medical teams. Aim of the present work is to develop a mechanism for a hospital bed by using pneumatic system which can be used in hospitals by surgery departments to help the medical teams to adjust the position or angle at which the patients need to be laid.

The design was carried out considering important variables like durability, safety, manufacturability, cost, ease of operation, patient functions etc., as in figure 1. The durability includes the longevity and lifespan of the bed under normal working conditions,

ranging anywhere from two to twenty years. Durability considers the material(s) from which the bed frame is designed, the reliability of the type of motors used in electronic beds, the ease of operating and maintaining the bed, cost of reparability amongst other functions. Safety in the hospital bed designs is of larger consideration because if the beds provided by hospitals do not promote a healthy lifestyle for recovery, the length of stay for the patients may be longer, injury may result to patient and/or staff and lawsuit liabilities are an option. The safety of each bed was determined by the material selections, compliance with local and international standards. For many reasons ease of manufacturing becomes very important in bed design for a number of reasons, most particularly the resultant profit margin that would result from the production ratio, number of workers needed, development of unique parts, etc. Manufacturability was determined by the reproducible components on each bed, difficulty for assembly, estimated number of workers to complete each bed and approximation of time for completion of each bed. Bed costs were considered in two folds. The first one was the

cost incurred towards manufacturing of parts, assembly whereas the second portion would be towards the procurement of bought out items.

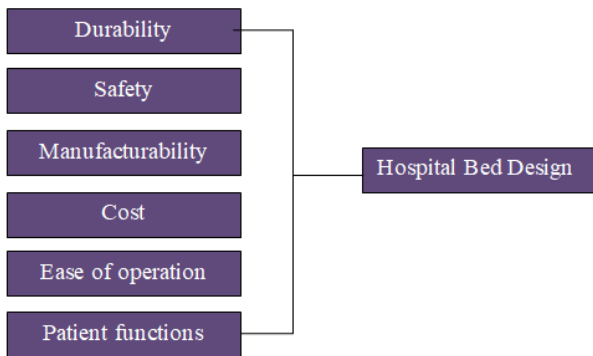

Figure 1. Major design considerations

As indicated in [2] the myths of pneumatic motion control and the research showed that pneumatic systems can be effective, economical and can carry heavy loads, if the system is designed properly and the pneumatic devices are chosen correctly. Ways of improving the efficiency has been studied by researchers and showed that certain factors such as size of pneumatic component, optimal pressure and minimizing the leaks can increase the efficiency of the system. Usage of the turning over mechanism in the medical bed to improve the comfortable level for the patients and to reduce nursing difficulty has been verified in the research [3]. Hospital beds should have a comfort level depending upon the condition of the patient and should have high efficiency. This increases the cost of the bed. Studies on using pneumatic actuators surpassing electrical actuators for hospital beds have shown reduction in cost [4]. Operating cost of pneumatic actuators can be reduce by selecting the right capacity compressor which saves power and prevent damage to the pneumatic equipment. Handling patients while transporting and shifting to bed becomes more challenging. Wheel chair used to transport patients could be converted into a bed by using of electrical motors or the mechanical linkages. The need of patients who are using wheelchair, to raise and lower the bed to the required position can achieved by using hydraulic system to increase the coefficient of comfort [5]. The mechanism and working principles by transforming wheel chair to a bed and vice versa was demonstrated in [6]. The methods of using pneumatic systems to carry load without failure has already been studied in research [7].

Materials and methods

The present work was focused on how a pneumatic system has been used in creating several movements for a medical bed. The bed can be moved in five directions and the system will not include electrical motor or a microcontroller. These movements in the bed will be helpful for the medical teams in the surgery rooms through placing the patient in several positions instead of using the physical forces to move the patients [8]. The design and force analysis of the bed has been carried out through PTC CREO software. The design and simulation of the pneumatic system that are used for movement of the bed is performed through FESTO Fluid software.

Mechanical design of the hospital bed

Based on the literature gathered from existing beds, design matrices have been developed to determine the critical parameters that would contribute to a reliable hospital bed. The major parts modeled are (i) Bed (ii) Base (iii) Universal joint and (iv) Double acting cylinder as shown in figure 2. Integrating all parts provides the required shape of the bed. These assembled parts are used in checking and simulating during the load analysis. The load analysis identifies the ability of selected material, design, and assembly whether it could withstand the load during maximum loading conditions. Underlying design of the hospital bed was considered under mechanical parts having three major tasks, which are base, universal joint, and the bed. Pressure required for moving the piston for the designed load is 4 bar. And so the pneumatic system needs to use a compressor which has the ability to supply 4 bar pressured air to the cylinders. The movement of the bed is limited to 500 mm by each cylinder. One-way flow control valves are adjusted in the pneumatic circuit to make the piston rods extend or retract in 7 seconds with the velocity V of 0.0714 m/s with a drop in pressure ΔP of 0.01753 bar.

$$\Delta P = \frac{7.57 * q^{1.85} * L * 10^4}{d^4 * P} \quad (1)$$

q Air flow rate in m^3/min

L Length of pipe in cm

d Inner diameter of the pipe in cm

P Pressure in bar

For the cylinder with 80 mm piston diameter and 20 mm piston rod diameter, and

with compression factor C_f of 5, the flow rate $Q = \frac{V \cdot C_f}{t}$ required to extend and retract are found to be 1.785 l/sec and 1.682 l/sec respectively. The valves need at least 0.9029 of volume coefficient C_v to extend and 0.85 of volume coefficient to retract for this double acting cylinder.

$$C_v = \frac{Q}{114.5} * \sqrt{\frac{T+G}{\Delta P \cdot (P_2 - P_a)}} \quad (2)$$

Where

G Specific gravity (1 for air)

T Temperature in K

P_1 Compressor capacity (4 bar)

P_a Atmosphere pressure (1 bar)

$P_2 = P_1 - \Delta P$

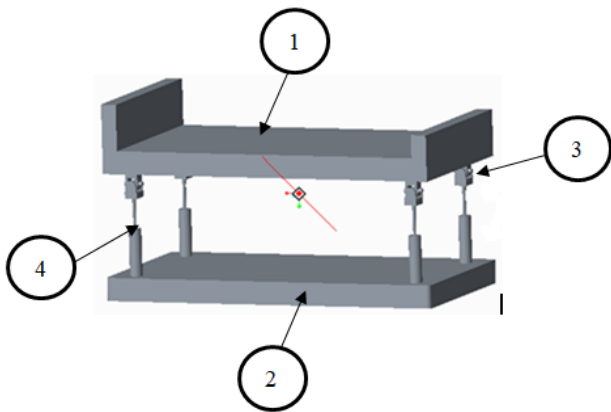

Figure 2. Mechanical design of hospital bed

Pneumatic system design

Pneumatic double acting cylinder has been utilized in the circuit to provide required movement in the bed. 5/2-way double piloted

valve controls the motion of the double acting cylinder by determining the direction of the compressed air entering into the cylinder. Also a 3/2-way valve with push button is connected with 5/2-way valve. It will supply the compressed air to 5/2-way valve in order to provide the extension and retraction to the double acting cylinder. One-way flow control valve is added to the pneumatic circuit in order to reduce the compressed air pressure which enters the double acting cylinders instead to apply the full pressure. This provides safe condition during changing position process because if the full pressure is applied to the system, the patient may fall down due to the high pressure force.

A shuttle valve has been used in the pneumatic circuit in order to make the compressed air flows from two different sources. And finally a check valve has been used in the pneumatic circuit to prevent the compressed air to flow in the reversed direction. So, it will prevent any clash to occur due to pressure when the pneumatic system is in operation. FESTO Fluid software has been used to simulate the pneumatic system. In the pneumatic system shown in figure 3, each double acting cylinder is connected to a specific location in the bed. Cylinder 1A is located at the higher right corner of the bed, cylinder 2A at higher left corner, cylinder 3A at lower right corner, and cylinder 4A at lower left corner.

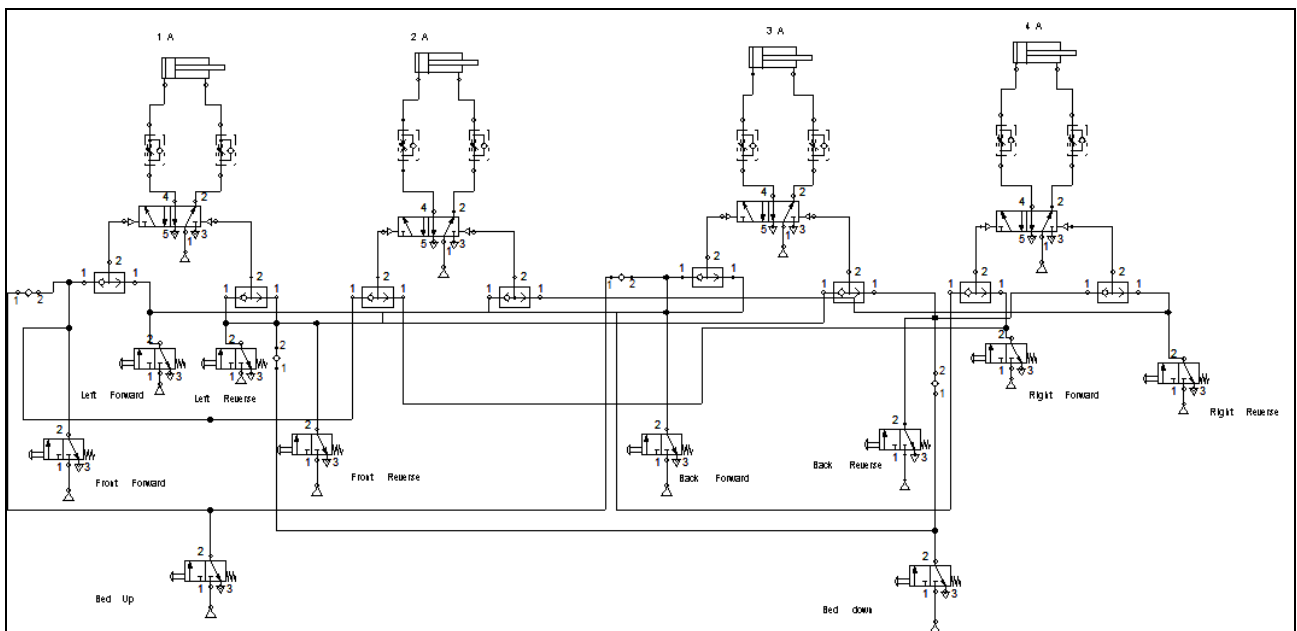

Figure 3. Pneumatic circuit in bed stable position

Figure 4 shows the changes in pneumatic circuit in each function of the hospital bed. In each function the required cylinders will extend their piston rods in order to raise the bed from the certain side. For example in front side inclination of the bed the cylinders 1A and 2A

will extend their piston rods to raise the bed from the front side and the other two cylinders will stay in their normal condition. Figure 5 to 8 shows activation of appropriate cylinder(s) for the required position of the bed.

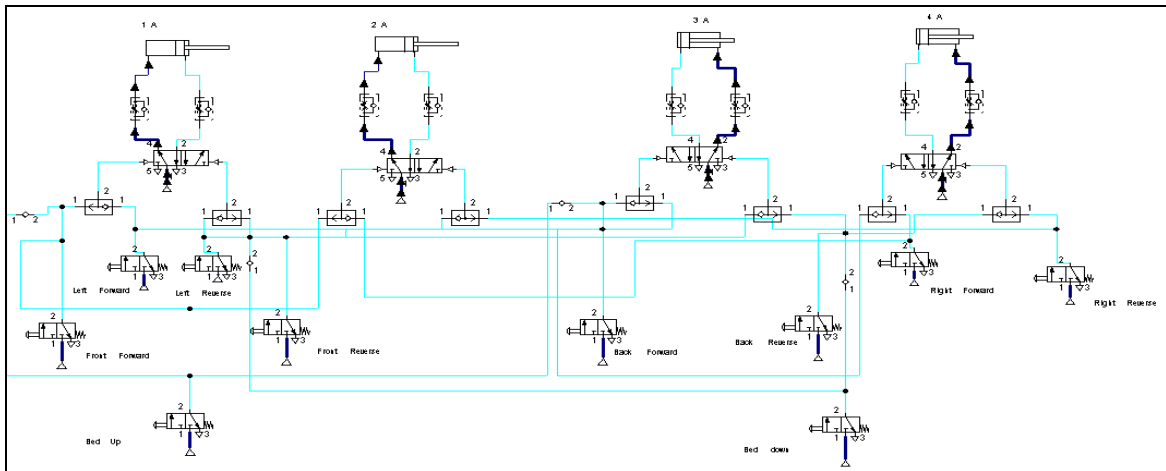

Figure 4. Front side inclination

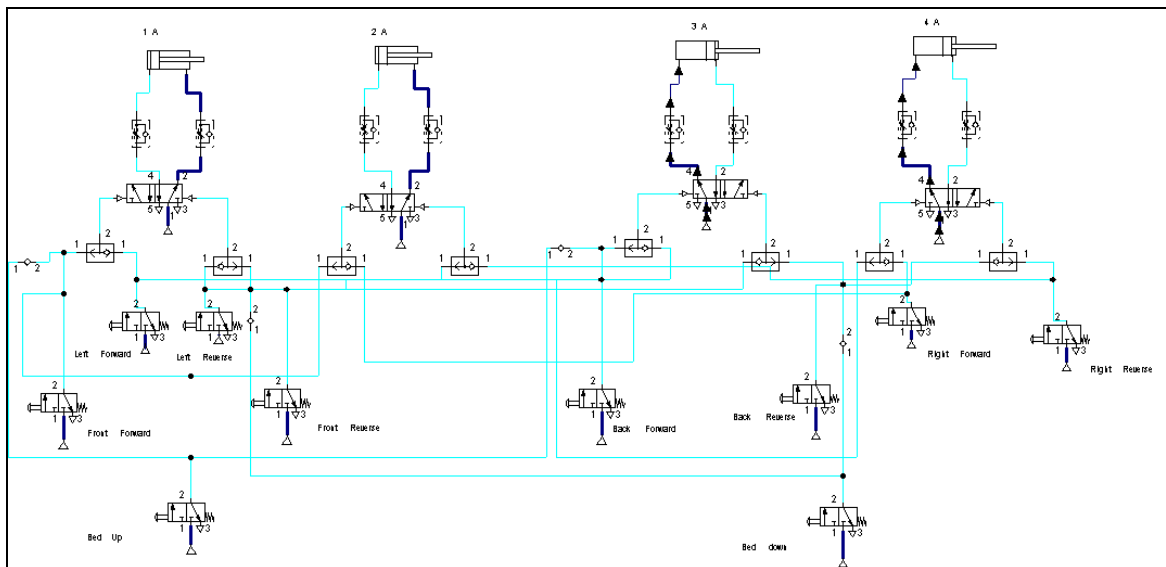

Figure 5. Back side inclination

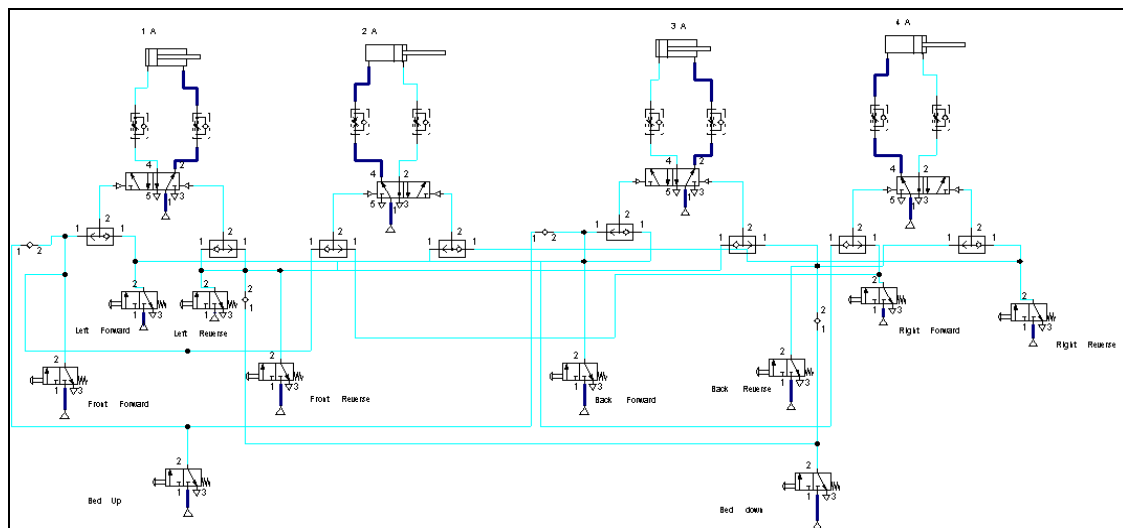

Figure 6. Right side inclination

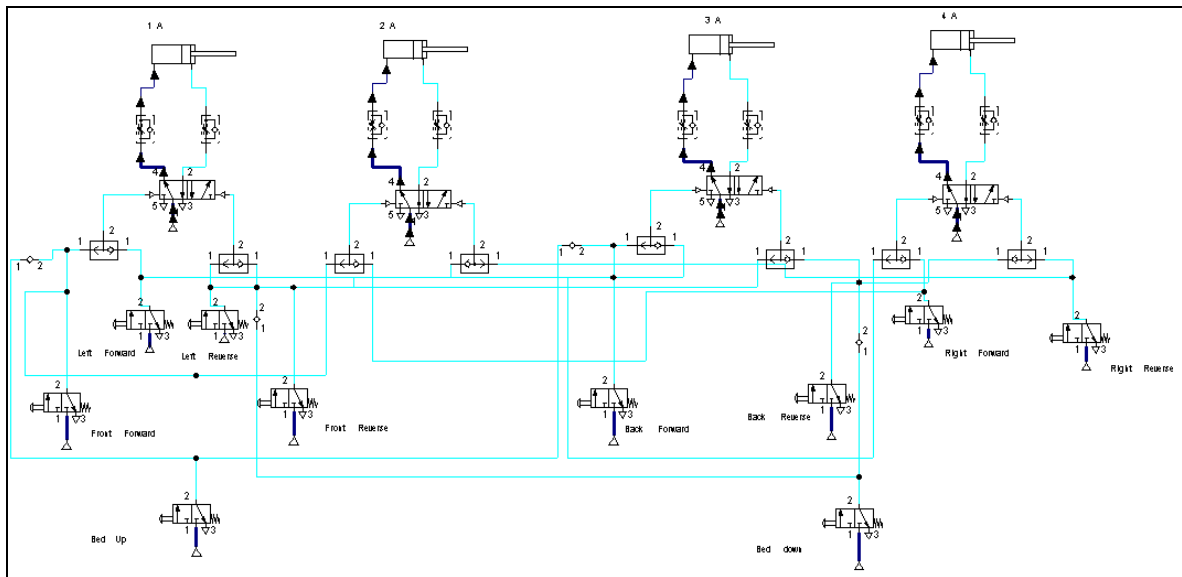

Figure 7. Left side inclination

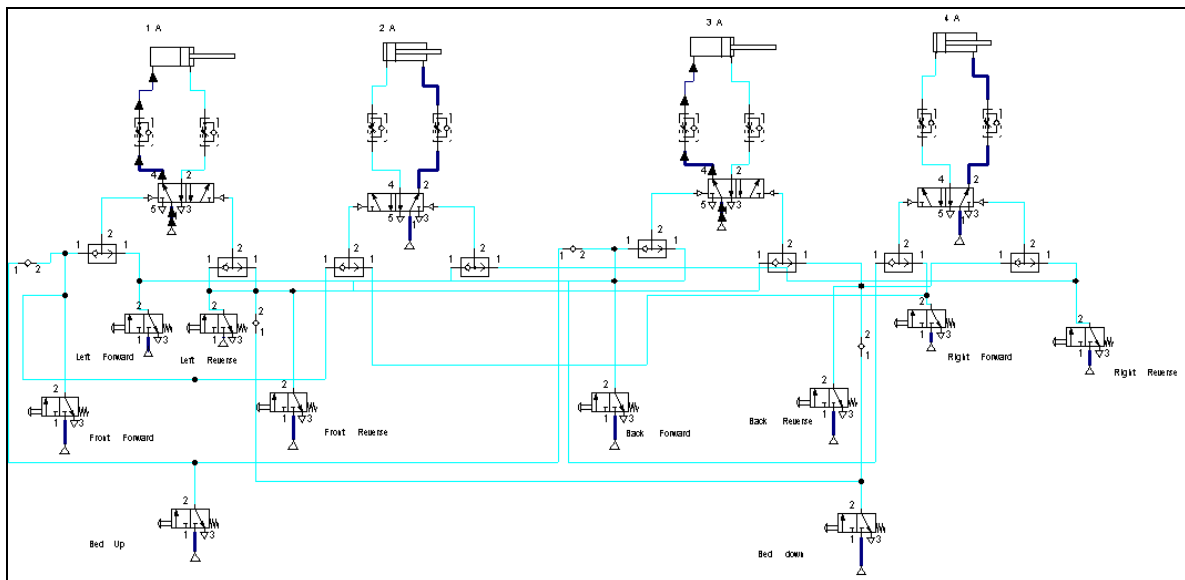

Figure 8. Pneumatic design for raise of bed

Results and discussions

Load Analysis

Usually stress analyses for any product are carried out on the weakest sections of the assembled part. In this case of medical beds though there are many critical parts that may be subjected to highest load, analysis was carried out on the bed where the patient will be laying on with applying full mass. So, the point of application of force will be on the bed as it is the main part where the mass of the patient gets distributed as in figure 9. The cylinder base is fixed and all degrees of freedom were arrested. Whereas the moveable part of the pneumatic cylinder where the load will be distributed is considered for analysis. The analysis in von-Misses stresses shows that the model can be

withstands the applied load (Figure 10). The highest stress value was at the central joint of the universal joints of 90.3 MPa (Figure 11).

In figure 12, the relation between Stroke length, piston rod diameter and critical force is shown. The double acting cylinders which have been used in this project having a piston rod diameter of 20 mm and stroke length of 500 mm. So, by using the graph the critical force which the double acting cylinder can lift is 2600 N. The calculated value of the maximum load that the double acting cylinder to lift was 1471.5 N. By comparing these results, it was found that this double acting cylinder can be used for the hospital beds. The reason of having a difference in values of maximum load is because that the manufactures usually consider that the

pneumatic system will be facing a friction factors and drop in the pressure.

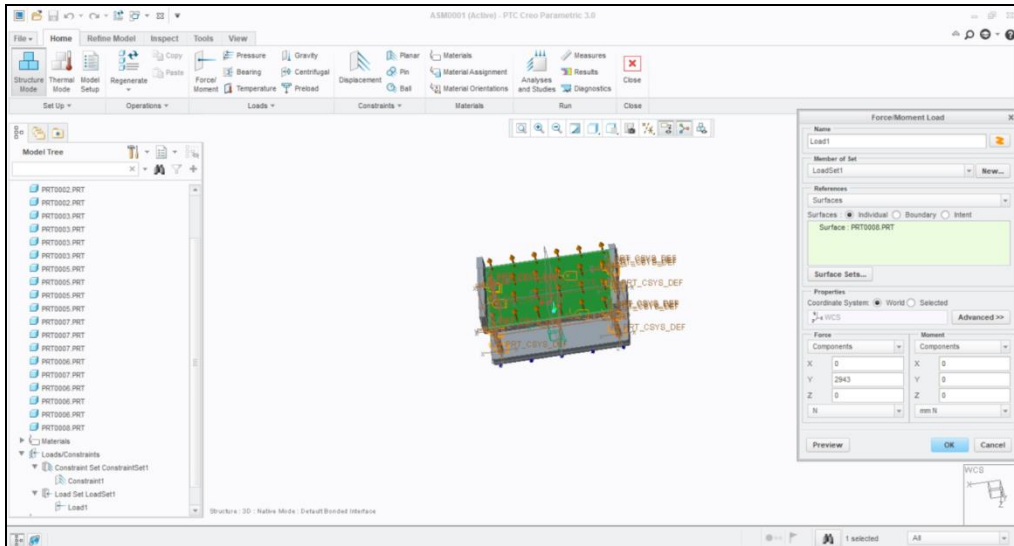

Figure 9. Point of application of forces

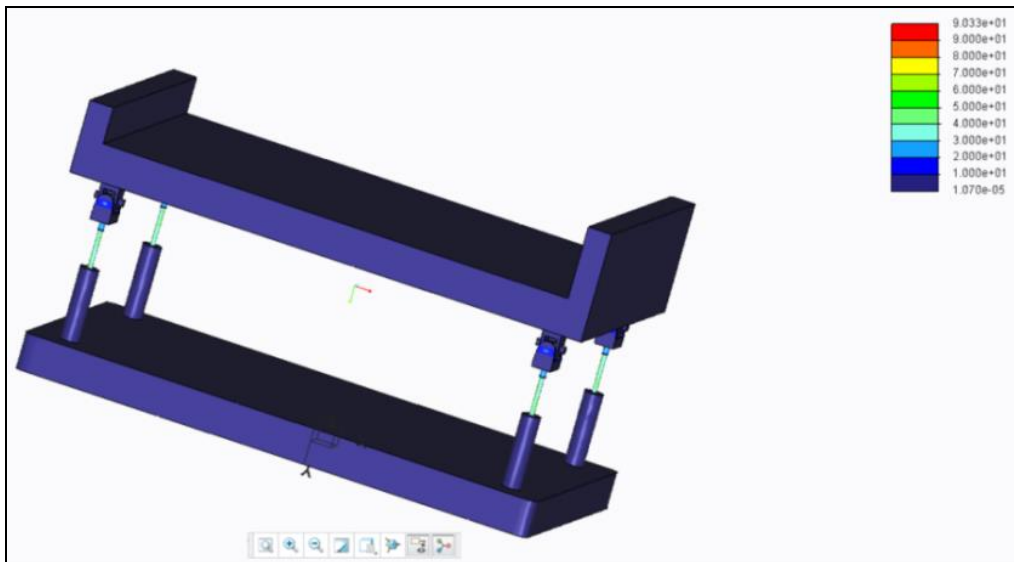

Figure 10. Von-Mises stress analysis

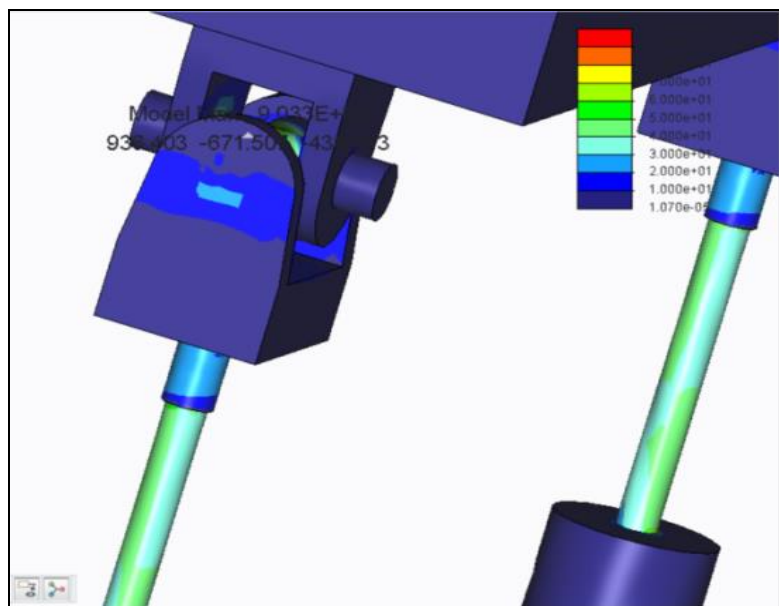

Figure 11. Maximum stress

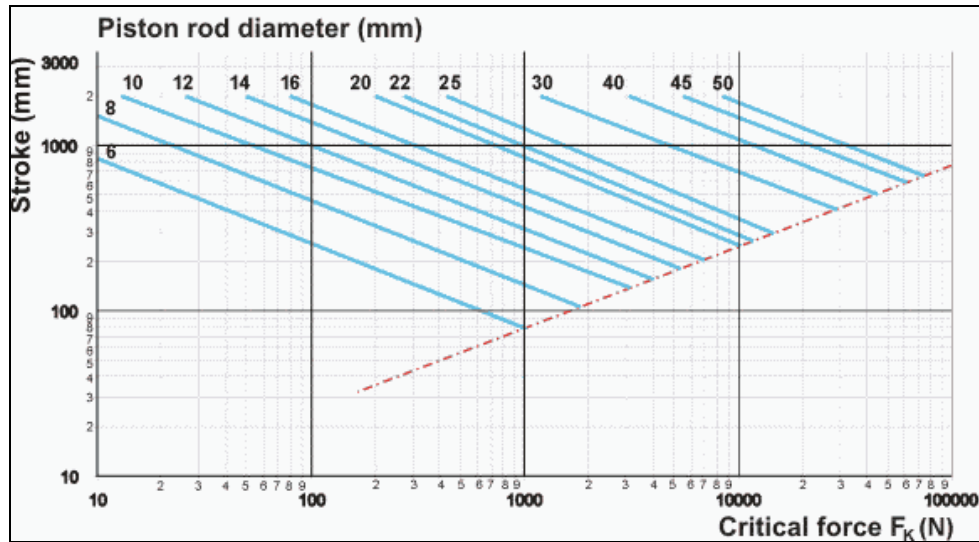

Figure 12. Stroke length, piston rod diameter and critical force relation diagram (Courtesy: Engineering Tool Box)

The results of the analysis have proved that the pneumatic system is safe to use in the hospital bed which can withstand a maximum load of 300 kg.

Conclusions

The mechanisms of hospital beds in current usage have been assessed by visiting several different government hospitals. The mechanism of the hospital bed in this paper has been developed through using pneumatic system. The pneumatic system has been created and simulated through using Festo fluid 3.6 Computer Software. Also the mechanism of the hospital bed has been designed and simulated through using PTC CREO computer software. The performance of the project has been evaluated through several methods of calculation then it had compared with the other hospital beds and some scientific charts. The cost of the hospital bed has been estimated by observing the prices of the parts and components in the markets. The results show that the selected double acting cylinder is capable of lifting the bed overcoming friction and pressure drop to achieve the required bed functions. Moreover, the total time taken in raising any side of the bed was around 8 to 9 seconds. In this work the total time to raise any side of the bed was found to be 7 to 8 seconds. A lot of pneumatic circuits designs have been tried before producing the final pneumatic circuit which can produce five different functions for the hospital bed with making sure that the pneumatic system will not make any risks for the people how are going to use it. This work will be very useful in the

surgery rooms in hospitals because it is operated by a clean and economic power which is air power. So, if any leakage happens in the system the compressed air will not pollute the place rather than using hydraulic system which may pollute the place, if leakage happens by its hydraulic oil. All the pneumatic components were inserted below the bed and this is ensuring that the valves, double acting cylinders, air pipes and air compressor will be far from the patients or kids. So, the hospital bed will be safe for using and it will not be dangerous for the users. The total cost of the project is 921.5 Omani Rials (2393.51 USD). This cost will be less if the hospital bed is produced in large volumes. The cost has been compared with the current hospital beds price and it was found that the price of the bed is 30 – 40 % less than the one commercially available in the market.

Conflicts of interest

No conflict of interest.

References

- [1] Ariyarit A, Kittipichai R. The Optimization Design of Hospital Bed Structure for Independently Separating Left and or Right Leg Using Genetic Algorithms. *Applied Mechanics and Materials* 2012;110-116:4276-83.
- [2] Howe, R Edwin. 5 Myths of Pneumatic Motion Control. *Hydraulics & Pneumatics*. 2004; 57,9:36.
- [3] Wang Yu-Zhao, Hang Lu-Bin, Cheng Wu-Shan, Lu Jiu-Ru, Ding Hong-Han. The Turning over Mechanism Designed for

- Rehabilitation Nursing Bed. Intl J Res Eng Sci 2015;3(91):1-5
- [4] Guajardo, Gil. Costs and Capabilities of Pneumatic, Electric Actuators. Industrial Maintenance and Plant Operation; Rockaway, 2016
- [5] Kulkarni SB, Thakare AJ, Tamann SH, Roman GS, Karankoti SV. Design and Fabrication of Wheelchair-to-Bed System Using Fluid Power. International Journal for Science and Advance Research in Technology 2016;2:13-18.
- [6] Meng N, Mengxi R, Qinglin F, Lizhi Z. Mechanism design of a robotic chair/bed system for bedridden aged. Advance in Mechanical Engineering 2017;9:1-8.
- [7] Dawid P. The characteristics of a pneumatic muscle. EPJ Web of Conference, 2017;143.
- [8] Sárosi J, Gyürky B. Design and Construction of a Humanoid Arm Driven by Pneumatic Muscle Actuator. Acta Technica Corvininensis 2016;9(4):49-52.
